

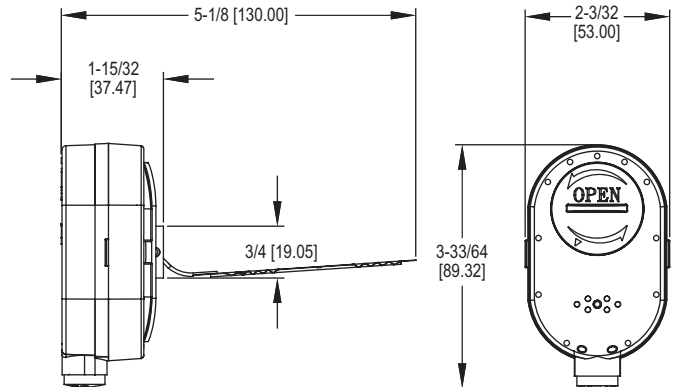

# Series DAFA Air Flow Indicator and Alarm

## Specifications - Installation and Operating Instructions



The **Series DAFA Air Flow Indicator and Alarm** alerts users of low or no air flow conditions in pipes utilizing a thin, field trimmable vane to sense the air flow rate. An 85 dB audible buzzer alternates with a bright red LED to alert users when the air flow rate drops, indicating low or no flow in the pipe. The DAFA is battery powered to provide versatility for where it can be installed, and offers a yellow LED to indicate a low battery. This device is ideal for monitoring radon mitigation systems by detecting a loss of air flow in the pipe and providing a signal to homeowners if the fan has stopped operating.

### MOUNTING

- Step 1: Drill a 3/4" hole in the system pipe
- Step 2: Clean the area of the pipe where the air flow monitor will be mounted.
- Step 3: If necessary, trim the vane as seen in Figure 1 for a 3" pipe.
- Step 4: Attach the vane to the body of the air flow indicator and alarm.
- Step 5: Peel the protective covering from the gasket.
- Step 6: Slide the vane through the 3/4" hole in the pipe and seal the gasket to the pipe.
- Step 7: Install the battery following the instructions in the Battery Replacement section of the manual.

### NOTICE

The flow switch has been designed to work in vertical pipes with the flow traveling upwards. Other configurations can lead to changes in the actuation / deactuation points.

### SPECIFICATIONS

- Service:** Clean air.
- Actuation Point:** 15 CFM (4" pipe); 10 CFM (3" pipe) on decrease in flow.
- Audible Alarm:** At least 85 dB @ 1 foot distance.
- Visual Alarm:** Red LED for no flow alarm; Yellow LED for low battery.
- Wetted Materials:** ABS, polycarbonate, rare earth magnet.
- Power Requirements:** 3 V CR2450 lithium battery, included, user replaceable.
- Battery Life:** 5 years steady state; 48 hours during alarm state.
- Temperature Limits:** 32 to 122°F (0 to 50°C).
- Mounting Orientation:** Vertical.
- Weight:** 4 oz (113.4 g).
- Agency Approvals:** CE.

### ALARM POINT

Visual and audible alarm cycle activates on decrease in flow at the points noted in Table 1.

Table 1: Alarm Points	
Pipe Size	Alarm Point
3"	10 CFM
4"	15 CFM

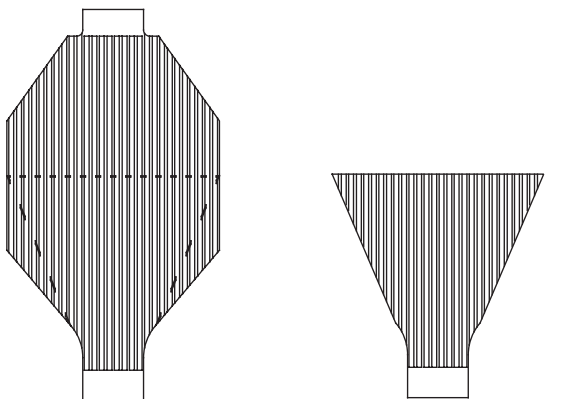

Figure 1: Trimming Vane for 3" Pipe

## OPERATION

The DAFA Air Flow Indicator and Alarm detects the air flow in a pipe by sensing the position of the vane. When the fan is operating normally, the flow will lift the vane in the upward position as depicted in Figure 2. As the air flow rate decreases the vane will drop down as depicted in Figure 3. If the air flow rate drops below 15 CFM in a 4" pipe (10 CFM in a 3" pipe), the red LED on the front of the device will illuminate to give a visual alert. If the flow does not regain within 30 s, the red LED will turn off and the audible alarm will sound for 10 s. The visual and audible indicators will alternate in this same pattern until air flow is regained or the battery is removed/drained.

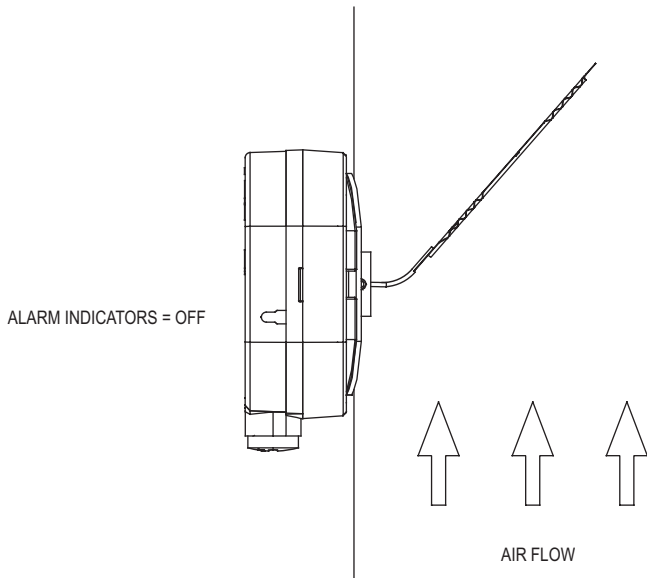

Figure 2: Vane Position Under Normal Flow Conditions

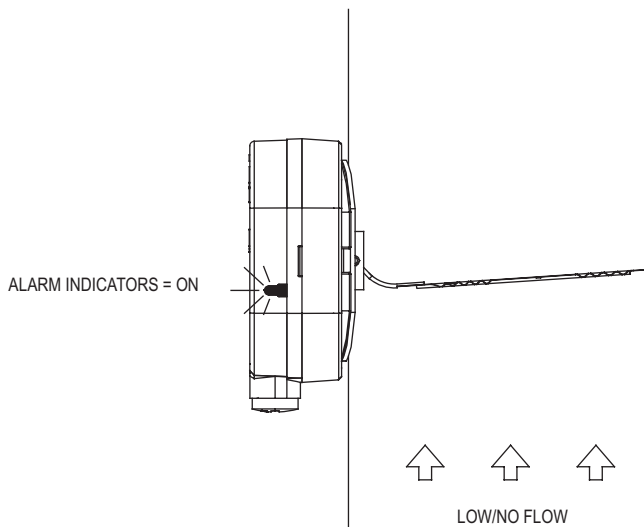

Figure 3: Vane Position Under No Flow/Alarm Condition

## AUDIBLE INDICATORS

No Air Flow: Off for 30 s; beeping for 10 s.  
Low Battery: Chirp every 5 minutes

## LED INDICATORS

No Air Flow: Solid red LED for 30 s; off for 10 s.  
Low Battery: Flashing yellow LED.

## TROUBLESHOOTING

- If fan appears to be operating and the DAFA Air Flow Indicator and Alarm is in the alarm state, check to see if the vane was installed properly. The vane should be able to travel in the direction of the air flow arrow.
- Next verify that there is no debris, moisture, or dust built up on the vane.
- Then check to see if the vane is hitting the wall of the pipe. If so, the vane may need to be trimmed.

## BATTERY REPLACEMENT

When the battery is low, a yellow warning LED will begin to flash and an audible alarm will sound every 5 minutes to alert that it is time to replace the battery. Using a large flat head screw driver, turn the battery cover 1/4 turn in the direction of the arrows on the cover. Remove the battery cover by lifting it up. Remove the coin cell battery from its compartment. Insert a new 3 V CR2450 coin cell lithium battery in the compartment with the positive (+) side of the battery facing up. Replace the cover and twist the cover using the large flat head screw driver in the opposite direction of the arrows.

## MAINTENANCE/REPAIR

Upon final installation of the Model DAFA, no routine maintenance is required. The Model DAFA is not field serviceable and is not possible to repair the unit. Field repair should not be attempted and may void warranty.

## WARRANTY/RETURN

Refer to "Terms and Conditions of Sale" in our catalog and on our website. Contact customer service to receive a Return Goods Authorization number before shipping the product back for repair. Be sure to include a brief description of the problem plus any additional application notes.